



# Vantage

Overcounter Electric



## Features:

- Only 54.61 cm (21.5") tall
- Four and five valve models
- Available with or without integral cold carbonator
- Stainless lower wrap
- Sculptured hood
- Drop-in refrigeration chassis
- Compact coil and valve assembly
- One piece lower housing
- 1/3 h.p. compressor
- Designed for high ambient use
- Durable stainless steel cabinetry



## Technical Specifications:

- Compressor:** 1/3 h.p.
- Condenser Finish:** Copper, aluminum
- Cup Clearance:** 24cm (9.75")
- Initial Average Icebank:** 6.4 kg (14 lb)
- Refrigerant:** R-134a
- Integral Carbonator Tank Reserve:** 1.65 L (56 oz.)
- Ice Bank Control:** Electronic
- Carbonator Pump Fill Rate:** 60 MI (2 oz./sec.)
- Syrup Inlet Fitting:** 1/4" barb
- Water Inlet Fitting:** 1/4" flare
- CO<sub>2</sub> Inlet Fitting:** 1/4" flare
- Valves:** Standard Flow
- Valve Types:** UF-1 or SF-1
- Draw Performance:** Number of drinks below 4.4°C (40°F)

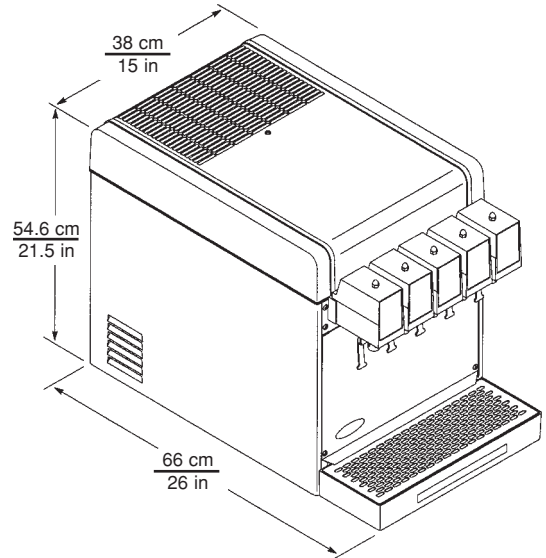

### Integral Carbonator:

- 24° C (75°F) ambient w / draw rate of two 355 MI (12 oz.) drinks per minute = 132
- 32° C (90°F) ambient w / draw rate of two 355 MI (12 oz.) drinks per minute = 65

### Remote Carbonator:

- 24° C (75°F) ambient w / draw rate of two 355 MI (12 oz.) drinks per minute = 193
- 32° C (90°F) ambient w / draw rate of two 355 MI (12 oz.) drinks per minute = 71

**Shipping Weight:** 44 kg (98 lb)

### Agency Listings:



Part No.	Description	Electrical
561600166	Vantage 4 Flavor, Integral Carbonator	115V / 60Hz / 7.4A
561600157	Vantage 5 Flavor, Integral Carbonator	115V / 60Hz / 7.4A
5616600164	Vantage 4 Flavor, Remote Carbonator	115V / 60Hz / 7.4A
5611600165	Vantage 5 Flavor, Remote Carbonator	115V / 60Hz / 7.4A
4923	4" Leg Kit	



For more information or to place an order, contact your sales representative or authorized distributor.

### In the US:

Phone: 1-800-238-3600  
Fax: 1-800-535-4235

[www.cornelius.com](http://www.cornelius.com)